

- DCM SDN Low-voltage Motor Cable (14/2 + 22/3 TWS)  
Part #9020126 Non-Plenum / #9020127 Plenum
- SDN Bus (CAT-5e or higher)
- 0-10V Input (18/2)
- 120V Power

**PROJECT NOTES:**

1. All Wiring will be supplied by ran, terminated and labeled by an ELECTRICIAN.
2. Final equipment parts and model numbers pending final design.
3. All local Fire and Electrical Codes are to be followed.

**MOTOR NOTES:**

AC Motor

- All AC Motors require 120V power; power line may be daisy chained to reduce wiring.
- All AC Motors require a power disconnect present at each Motor

DC Motor

- Max distance from Power Panel #1870259 to DC Motor is 240' [73m] when using the SDN Low-voltage Motor Cable (Non-Plenum #9020126 or Plenum #9020127)

**EQUIPMENT NOTES:**

0-10V Interface V2 #1870857

- Bus Power from 0-10V Interface V2 must be switched ON when connecting to Bus Port on SDN Device.
- The 0-10V and line voltage inputs for 0-10V Interface V2 are required from the Third Party 0-10V connection.
- Max distance from Third Party is 100' [30m].
- Max distance from Device Port is 200' [60m].

Data Hub #1870262 and Mini Data Hub #1870277

- All Data Hubs require Bus Power from (1) 0-10V Interface V2 per System.
- Max distance from connected Device is 200' [60m].
- If installed in a Junction Box it must be a minimum of 6" x 6".

Power Panel #1870259

- All Power Panels require Bus Power from (1) 0-10V Interface V2 per System.
- Each Power Panel will require a hardwired 120V connection to be provided and terminated by an ELECTRICIAN; (1) Power Panel per Dedicated 15 Amp Circuit or (2) Power Panels per Dedicated 20 Amp Circuit.

SDN Decoflex Keypad

- All Keypads require a 1-Gang Back Box to be supplied and installed by an ELECTRICIAN; all Back Boxes should have adequate depth (~3") to support an RJ-45 connection to the back of the Keypad.

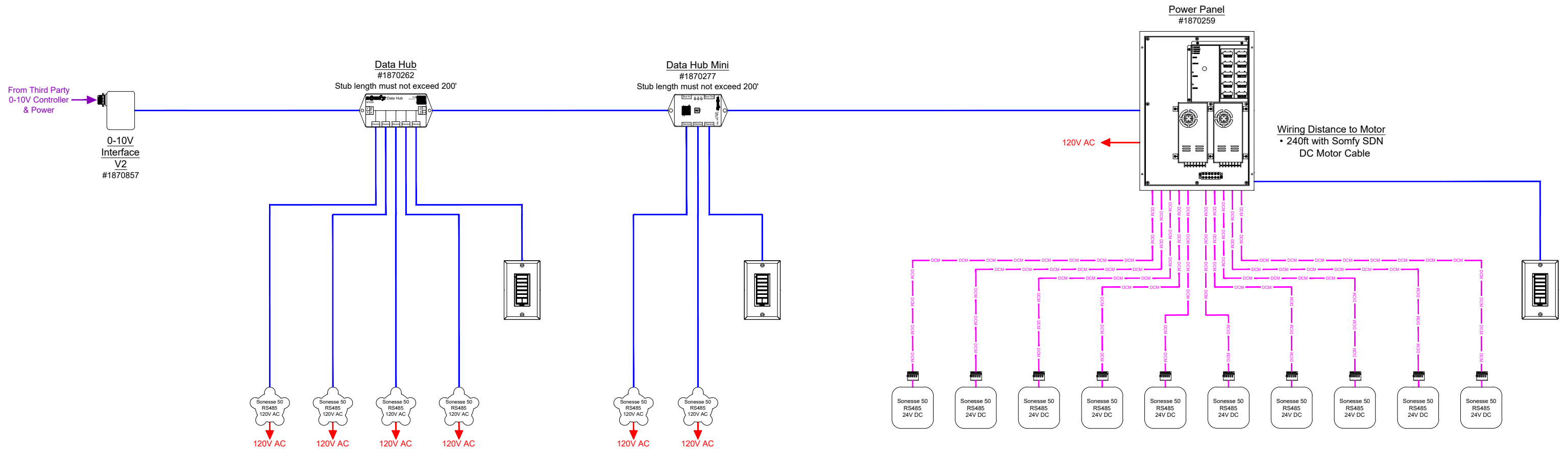

- All 0-10V (V2) Interfaces are installed (in an accessible location and manner for final configuration and programming) and powered.
- Motor All Configuration will communicate on the SDN bus using the Broadcast Address.
- In this Configuration, the 0-10V Interface provides bus power for the SDN Segment.
- Please reference the Programming Guide available on the product page at [somfysystems.com](http://somfysystems.com).

© 2015 Somfy Systems, Inc. All Rights Reserved. This drawing is the property of Somfy Systems, Inc.. The graphics, information and specific ideas in this document are the exclusive property of Somfy Systems, Inc. and must not be made public, copied, or sold. Others seeking permission to reproduce this document, in whole or in part, must obtain permission from Somfy Systems, Inc. in writing.

Tel: 1-800-64-SOMFY  
Fax: 1-609-495-8165  
[www.somfysystems.com](http://www.somfysystems.com)



Date:	06/02/22	Rev	Date	By	Description
Print Size:	11" x 17"	-	--/--/--	-	
Scale:	NTS	-	--/--/--	-	
Sales:	N/A	-	--/--/--	-	
Drawn by:	RV	-	--/--/--	-	
Checked by:	PK	-	--/--/--	-	

Dwg Title:	0-10V Interface V2 SDN via Bus Port System Overview
Dwg No.:	10vV2-SYS-01

Project name:	Technical Library
Client:	Somfy Systems, Inc.
Address:	121 Herrod Boulevard Dayton, NJ 08810