

Somfy CT-32RT-12V Motor

Fabrication / Assembly Instructions

Springs NEW Easy Up Headrail with 'Traversing Rod' Spooling System

Using Adapter # 2330090 4mm Sq Shaft Adapter

2330152 Headrail Adapter

SYSTEMS COMPONENTS

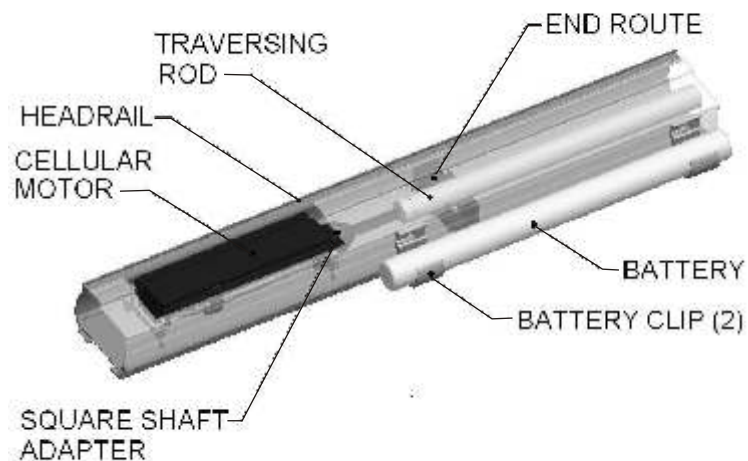

- 1) Before beginning motor installation, verify that End Route is at least **8 inches** in from the Headrail end. If End Route is less than 8 inches from the end of the Headrail, the motor will not fit completely inside of the shade Headrail. **See Figure 1.**

FIGURE 1.

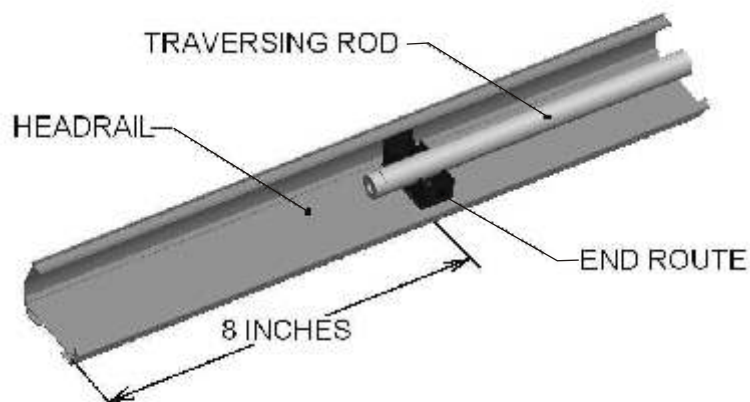

- 2) To begin motor installation procedure, ensure that shade internal drive assembly is as shown in **Figure 1**. If a manual pull clutch assembly is installed, remove this item and its associated hardware. Save the square drive shaft for use in the motorized assembly.
- 3) Press fit Square Drive Shaft into Adaptor Square until collar bottoms out on adapter as shown in **Figure 2**.

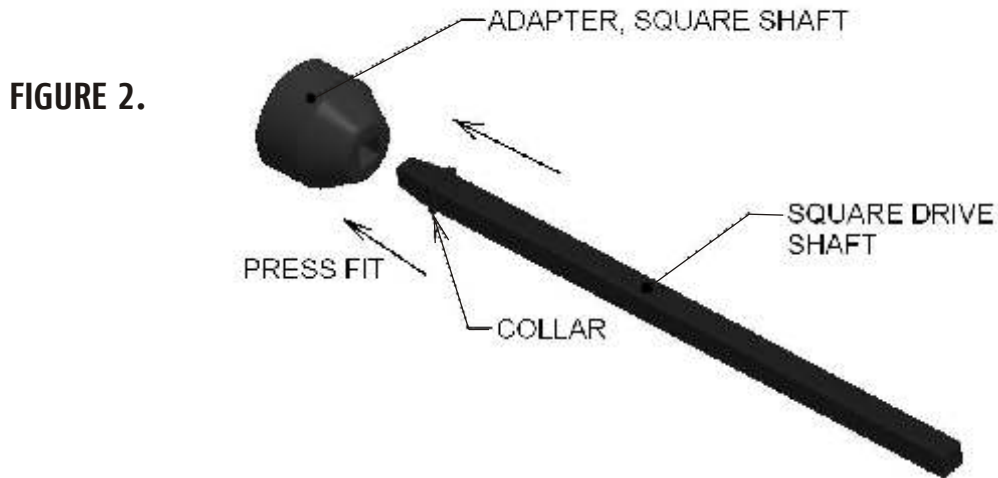

- 4) Slide the Adapter Square Shaft Assembly into the Square hole of the Traversing Rod. Make sure the shaft slides smoothly in and out of Traversing Rod. **See Figure 3.**

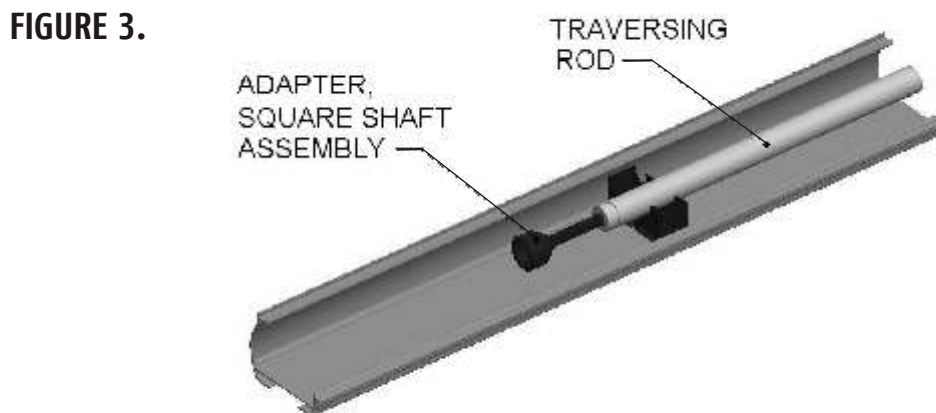

- 5) Attach Motor Headrail Adapters to CT32 Motor as shown in **Figure 4**. Motor Adapter holes snap onto "Pins" on CT32 Motor case. Ensure that adapters are oriented as shown so that the motor will align with the Traversing Rod.

FIGURE 4.

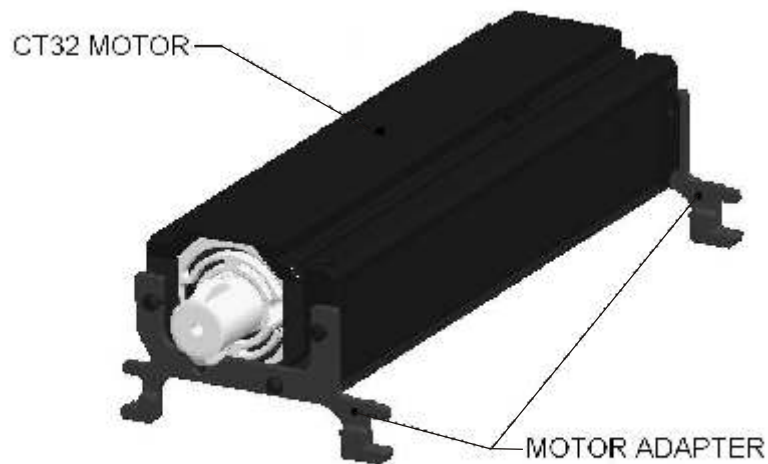

- 6) Slide Motor with Headrail Adapter into the Headrail Slot as shown in **Figure 5**. Align Motor Drive Rod Flanges with Slot in the Square Shaft Motor Adapter. Slide motor in until the Drive Rod Flanges "snap" into the slot of the Motor Adapter.

FIGURE 5.

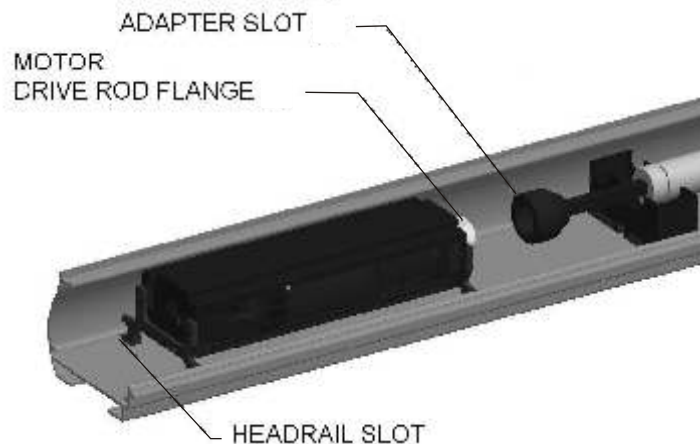

- 7) The cover will need to be modified in order to accommodate the motor. Cut Headrail cover approximately as shown in **Figure 6** in order to accommodate the motor profile.

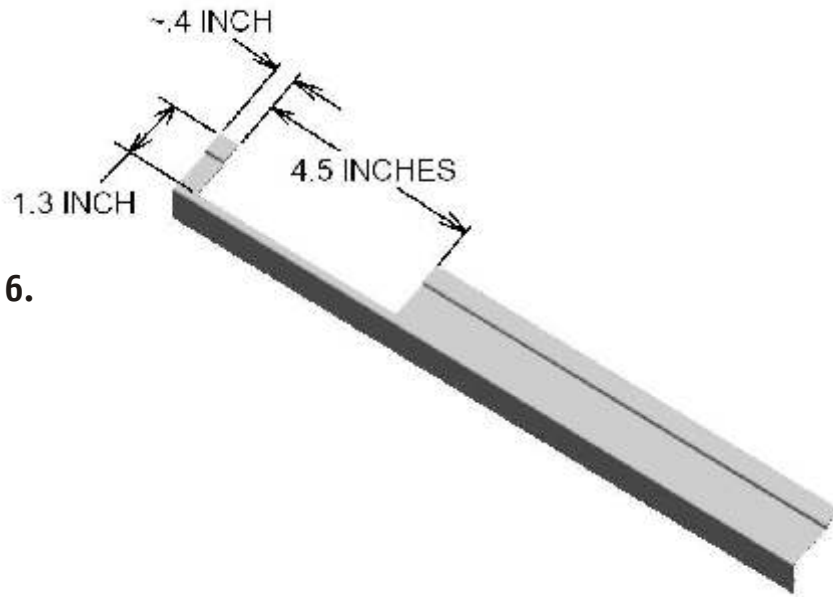

FIGURE 6.

- 8) Install Headrail Cover onto Headrail and trim motor and cutout if needed.
- 9) Attach battery clips to back side of Headrail Cover using double sided attach foam. Ensure that surfaces are clean of oils and residue prior to attaching foam. Use alcohol or glass cleaner if needed to clean surface. **Important:** Make sure the battery is located in a position that does not interfere with the Headrail Mounting Brackets. **See Figure 7.**

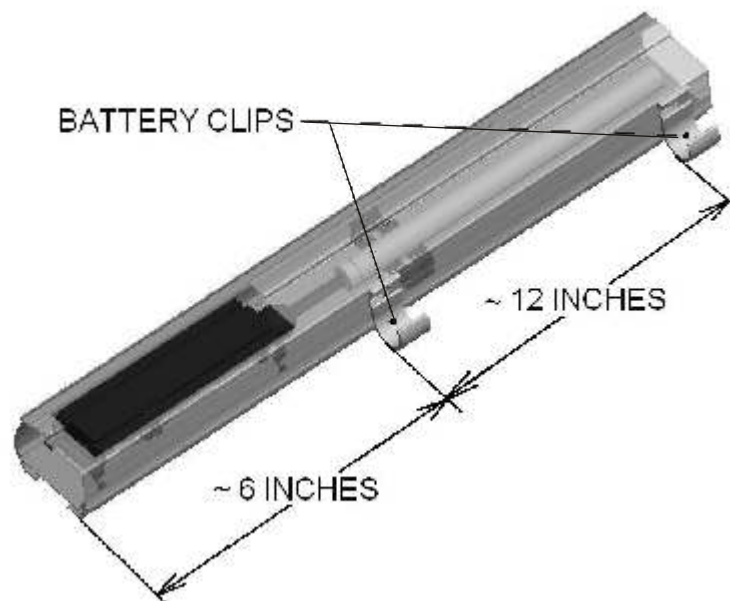
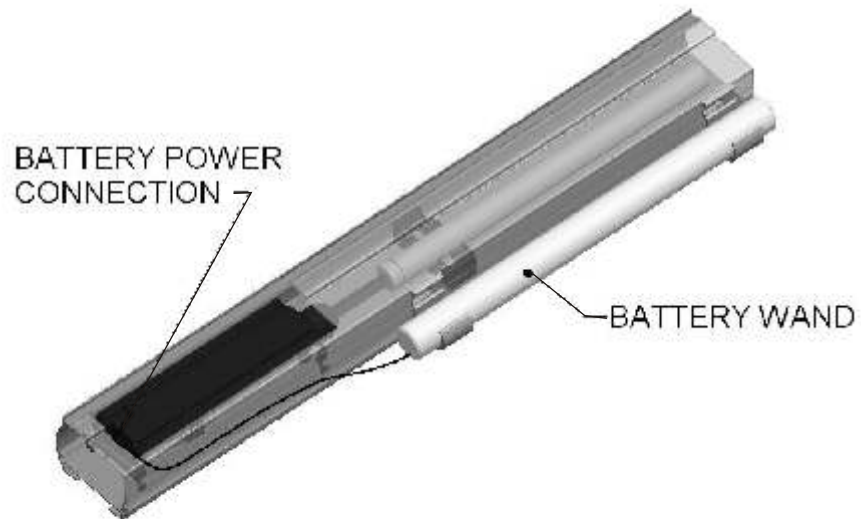

FIGURE 7.

- 10) Slide Battery Wand into Battery clips as shown in **Figure 8**. Attach battery power cable to motor. Battery connector is keyed to ensure proper power connection.

Figure 8



- 11) Attach Headrail End Cap as shown in **Figure 9**. Shade is now ready to be installed and programmed for operation.

Figure 9.

