

somfy®

Programming Guide

Somfy Digital Network™ (SDN) Keypad Configuration Software



Programming Guide

Somfy Digital Network™ (SDN) Keypad Configuration Software

Rev C | March 2019 | Prepared by Project Services

Contents

I.	Parts Needed -----	3
	Software	
	Hardware	
II.	Software Installation -----	3
III.	Explanation of User Interface -----	4
	Configuration Section	
	Button Programming Section	
	Command Options	
IV.	Programming -----	7
	Programming a Keypad for Basic Functions	
	Use Switch Address	
	<i>* This section pertains only to Keypad <u>Firmware</u> Version 5.5</i>	
	Popular Programming Options	
	1-to-1 Configuration	
	Programming a Keypad for Group Functions	
	<i>* This section pertains only to Keypad <u>Firmware</u> Version 5.5 with Keypad Configuration <u>Software</u> Version 5.7</i>	

I. Parts Needed

Software:

- Somfy Digital Network™ (SDN) Keypad Configuration Software

Hardware:

- USB to RS-485 Converter for SDN (Somfy Part #9015260)
- SDN DecoFlex Digital Keypad (Somfy Part #1811252, 1811311, 1811334, 1811253, 1811312, 1811335, 1811749, 1811750)
- Bus Power Supply (Somfy Part #1822440)
- Category 5 or higher patch cable terminated TIA 568B – Suitable length to connect PC to SDN Bus
- Laptop PC

II. Software Installation

1. Download the latest SDN Keypad Configuration software.

**When possible, install as administrator.*

This can be downloaded from:

<https://www.somfysystems.com/support/tools/configuration-tools-software>

1. Connect the USB to RS-485 converter to any USB port on your laptop.
2. Go to Windows Start menu and search for Device Manager and open the program.
3. Go to Ports and click to expand it.
4. Make note the COM Port number listed for the RS-485 port.
Note: If RS-485 Port is not listed under "Ports", you must install the driver for the USB to RS-485 Converter.
This can be downloaded from:
https://support.advantech-bb.com/download?product_model_name=BB-485USB9F-2W-LS#Driver

5. Right click on the RS-485 Port and click Properties.

7. Click the tab for Port Settings, and confirm the Settings are as follows:

- Bits per second: 4800
- Data Bits: 8
- Parity: Odd
- Stop Bits: 1
- Flow Control: None

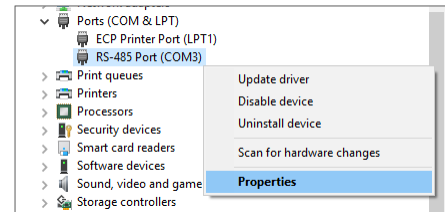

8. Open the Somfy Digital Network™ (SDN) Keypad Configuration Software from the Desktop icon or Windows Start menu.

9. At the top left of the window, select the COM port that you noted from the Device Manager and click on the "Connect" button. You are now connected to the COM port.

Note: If there is no COM ports listed in the dropdown box, close the software and make sure the USB cable is connected, and then reopen the software. If there still is no COM port listed, reinstall the driver for the USB to RS485 adapter. Be sure the Keypad Config is the only software running on your computer. Also, if you can not connect to the COM port, make sure that no other software is using that COM port.

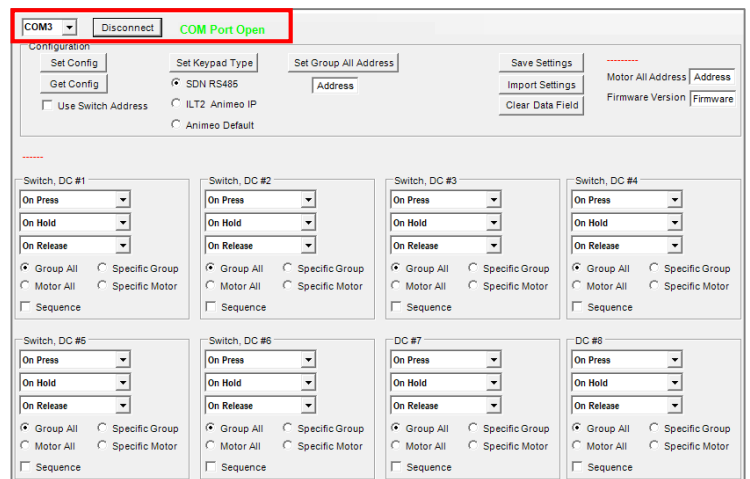

III. Explanation of User Interface

Configuration Section:

- *Set Config* – Sends all the programming on screen, to the Keypad.
 - *Get Config* – Checks and displays all that is currently programmed to the connected Keypad.
 - *Set Keypad Type* – Allows you to change the Keypad to either an SDN or animeo IP Keypad with default configuration. (Only available if keypad is running Firmware version 5.0 or higher)
 - SDN RS485 – Sets the Keypad to work with standalone SDN systems
 - ILT2 animeo IP – Sets the Keypad to work with ILT2 Motors and animeo IP
 - Animeo Default – Programs the Keypad with the default configuration for animeo IP Keypads
 - *Set Group All Address* – Allows you to enter a group address for the keypad to control. This also will be used as the Keypad’s address. When using animeo IP Keypad programming, each Keypad will need a unique address in this field.
 - *Save Settings* – Will save all programming made onscreen, to a text file.
 - *Import Settings* – Will import settings from a previously saved file.
 - *Clear Data Field* – Clears all values onscreen.
- Note:** This does not clear the Keypad, unless you then press the Set Config button.
- *Motor All Address* – This is used when making a Keypad for testing/troubleshooting to control all motors on the system. Type “FFFFFF” in this box and select the *Motor All* radio button in the button boxes below. This field can also be populated with any motor address and when the *Motor All* radio button is selected on that switch button, it will communicate with that address.

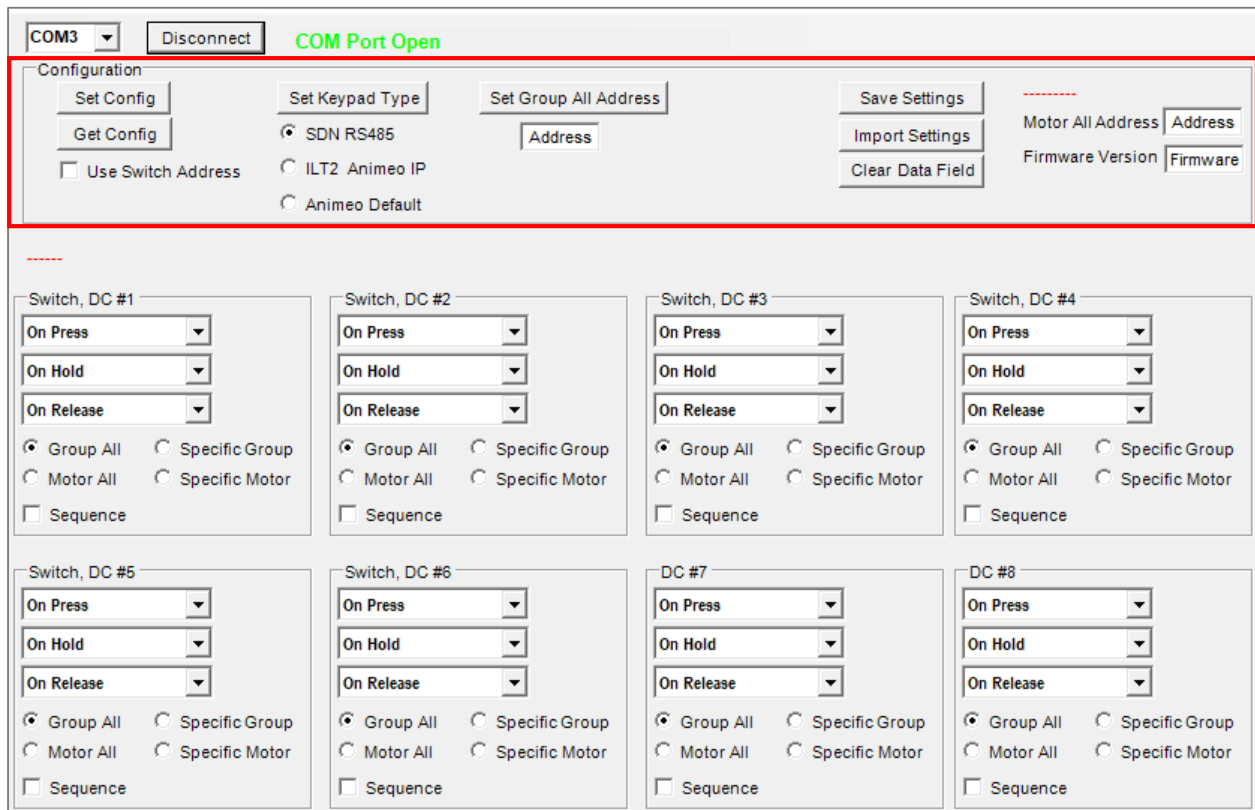

Keypad Button Programming Section:

- Each Keypad Button is represented by a window labeled "Switch, DC #_".
 - Note:** When programming a 6-Button Keypad, "Switch, DC #4" and "Switch, DC #5" are not used, unless for Dry Contact closures on the back of keypad.
- Each Keypad Button has a dropdown to program a command to happen when you Press, Hold, or Release the button on the Keypad. (If you want nothing to happen when you Press, Hold or Release the button, then just leave the dropdown to say "On Press", "On Hold" or "On Release")
- Each section has a *Sequence* check box. When selected, it will turn the section of that Keypad Button purple. This option will enable sequential commands/functions.

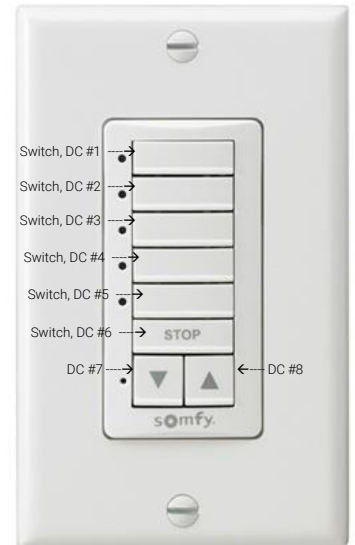

[See "Switch, DC #5" below] The first dropdown box command (A) will act on the first button press, the second dropdown box command (B) will act on the second button press, and so on, that each press on that Keypad Button will cycle commands from **A - B - C - B - A**.

Note: During operation mode, 60 seconds after the last Keypad Button is pressed, the second dropdown box command (B) will be skipped; The Sequence function is not supported on button #6-8 once the "Group" selection is made in any of buttons #1-5.

- Each section has a choice of four radio buttons. These options will tell each Keypad Button which Motor or Group to send a command to.
 - Group All* – Makes this Keypad Button control all Motors in the "Set Group All Address" box [See "Switch, DC #1" below]
 - Motor All* – Makes this Keypad Button control all Motors in the "Motor All Address" box [See "Switch, DC #2" below]
 - Specific Group* - Makes this Keypad Button control only the Motors in the specified group [See "Switch, DC #3" below]
 - Specific Motor* - Makes this Keypad Button control only the single specified Motor [See "Switch, DC #4" below]

Command Options:

- *On Press* is a placeholder to show where the dropdown is for programming the *On Press* feature. When changed to a function in the dropdown box, this button will activate the function. When *On Press* is left in the dropdown box, nothing will happen when the button is pressed.
- *On Hold* is a placeholder to show where the dropdown is for programming the *On Hold* feature. When changed to a function in the dropdown box, this button will activate the function. When *On Hold* is left in the dropdown box, nothing will happen when the button is pressed. **Note:** A hold is defined as a press that lasts more than 1.5 seconds.
- *On Release* is a placeholder to show where the dropdown is for programming the *On Release* feature. When changed to a function in the dropdown box, this button will activate the function. When *On Release* is left in the dropdown box, nothing will happen when the button is pressed.
- *Up* – Sends motor/groups up to the upper limit.
- *Down* – Sends motor/groups down to the lower limit.
- *Stop* – Stops motor/group movement
- *Go to IP #* – Sends motor/group to a specific IP (Intermediate Position).
- *Next IP Up* – Sends motor/group up to next IP position programmed in the motor.
- *Next IP Down* – Sends motor/group down to next IP position programmed in the motor.
- *Go to Pulse #* – Sends motor/group to specified pulse #.
- *Jog Up X 10 ms* – Sends motor/group up 10 times milliseconds specified.
- *Jog Down X 10 ms* – Sends motor/group down 10 times milliseconds specified.
- *Jog Up Pulse* – Sends motor/group up specified # of pulses.
- *Jog Down Pulse* – Sends motor/group down specified # of pulses.
- *Go to %* – Sends motor/group to specified %.
- *Lock @ Current* – Locks motor/group at current location. (be sure to program a button to Unlock at the same or higher priority)
- *Lock @ Up* – Locks motor/group at upper limit. (be sure to program a button to Unlock at the same or higher priority)
- *Lock @ Down* – Locks motor/group at lower limit. (be sure to program a button to Unlock at the same or higher priority)
- *Lock @ IP #* – Locks motor/group at specified IP. (be sure to program a button to Unlock at the same or higher priority)
- *Unlock* – Unlocks motor/group that has been locked (The highest priority lever of lock/unlock is #255).
- *Set IP #* – Programs current location as specified IP #.
- *Group* – (See “Group Programming” Section IV)

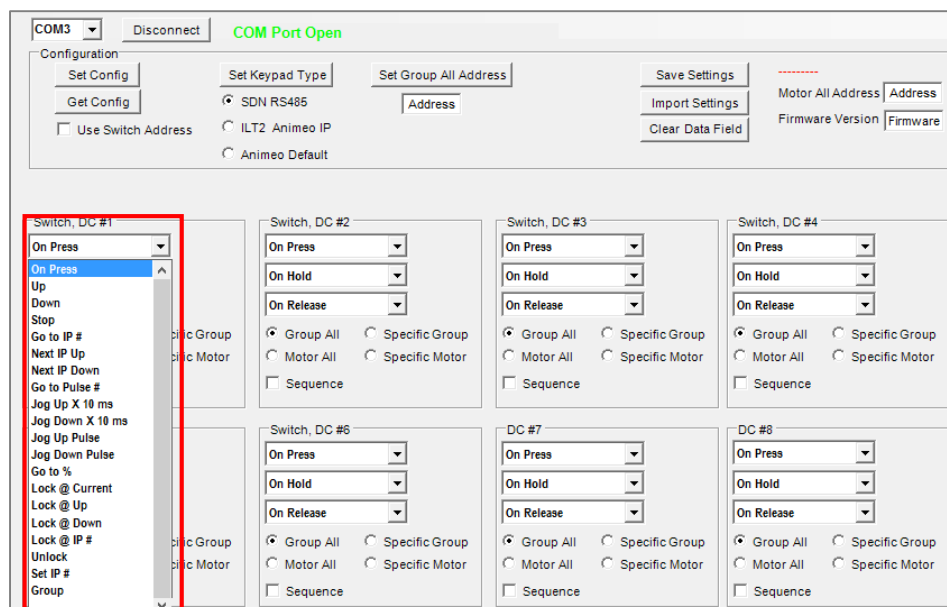

IV. Programming

Programming a Keypad for Basic Functions

1. Connect the USB to RS485 converter to the computer's USB port (see picture below)
2. Connect a CAT-5e or higher cable to the RS-485 Converter and Data Pass-through port on the Bus Power Supply
3. Connect Keypad to the Bus Power Supply Power/Data port with a CAT5 or higher cable
4. Connect Bus Power Supply to 120v outlet

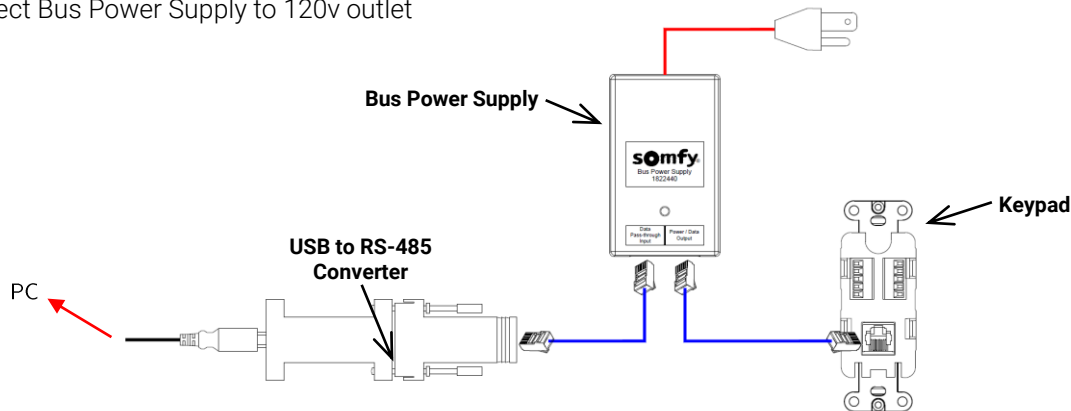

5. Open Somfy Digital Network™ (SDN) Keypad Configuration Software
6. Click the dropdown and select the correct COM port and click Connect
7. In the "Set Group All Address" box, type in the group address that you would like this Keypad to control
8. For "Switch, DC #1" change the *On Press* dropdown to *Go to %* and in the box that appears to the right type "15"
9. For "Switch, DC #2" change the *On Press* dropdown to *Go to %* and in the box that appears to the right type "30"
10. For "Switch, DC #3" change the *On Press* dropdown to *Go to %* and in the box that appears to the right type "50"
11. For "Switch, DC #4" change the *On Press* dropdown to *Go to %* and in the box that appears to the right type "70"
12. For "Switch, DC #5" change the *On Press* dropdown to *Go to %* and in the box that appears to the right type "85"
13. For "Switch, DC #6" change the *On Press* dropdown to *Stop*
14. For "Switch, DC #7" change the *On Press* dropdown to *Down*
15. For "Switch, DC #8" change the *On Press* dropdown to *Up*
16. In each switch box make sure that the radio button for "Group All" is selected
17. Click on the "Set Config" button. While the program writes to the Keypad, the light on the front of the Keypad will flash. DO NOT DISCONNECT the Keypad until after the light goes out. (about 5 seconds)

Note: When using Keypad Configuration Software 5.7, a pop-up warning will appear following step 17. Press "OK", and then reference the "Use Switch Address" Section on the next page for more information on this feature.

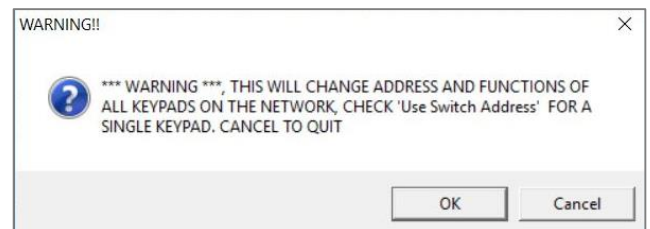

You are now finished programming.
Connect the Keypad to any Device Port on the SDN network to control the Group you programmed.

Use Switch Address

* This section pertains only to Keypad Firmware Version 5.5

- “Use Switch Address” will allow you to communicate to a single Keypad on the bus without isolating the Keypad:
 - If you DO NOT know the Switch address –
 1. Connect to a single Switch/Keypad
 2. Press the *Get Config* button
 3. The box below *Set Group All Address* will display the Keypad’s address
 - If you DO know the Switch address –
 1. Connect to a single Switch/Keypad
 2. Check the “Use Switch Address” box
 3. Enter the Switch/Keypad address in the box under the *Set Group All Address* button
 4. Program the Switch/Keypad accordingly
 5. Press the *Set Config* button

Popular Programming Options

- Program a momentary button to only move up or down while the button is depressed:
 1. Change the *On Press* dropdown to *Down or Up*
 2. Change the *On Release* dropdown of *Stop*
- Create a single Keypad button to command Up, Stop & Down:
 1. Check the Sequence box under the Keypad button you want to program
 2. Change the *On Press* dropdown to *Up*
 3. Change the *On Hold* dropdown to *Stop*
 4. Change the *On Release* dropdown to *Down*
- Dedicate a single 6-Button Keypad to move a specific group up, down or to a specific % at the same time:
 1. Select the *Specific Group* radio button option on each Keypad Button section
 2. Enter the same Group Address on each section
 3. For “Switch, DC #1”, change the *On Press* dropdown to *Go to %* and in the box that appears to the right, type “25”
 4. For “Switch, DC #2”, change the *On Press* dropdown to *Go to %* and in the box that appears to the right, type “50”
 5. For “Switch, DC #3”, change the *On Press* dropdown to *Go to %* and in the box that appears to the right, type “75”
 6. Keep “Switch, DC #4” as is
 7. Keep “Switch, DC #5” as is
 8. For “Switch, DC #6”, change the *On Press* dropdown to *Stop*
 9. For “Switch, DC #7”, change the *On Press* dropdown to *Down*
 10. For “Switch, DC #8”, change the *On Press* dropdown to *Up*

1-to-1 Configuration (1 Motor powers 1 Keypad)

- To program a momentary button to only move up or down while the button is depressed:
 1. Using the Grey Motor Data Cable with Power, connect Somfy Keypad (#1811730) directly to a 120V AC RS-485 Motor
 2. The Keypad will need to be programmed with the Motor’s address, a group address that is programmed in the Motor, or the FFFFFFFF address
 3. The Keypad buttons can be programmed in any configuration just like all other SDN Keypads (see “Keypad Button Programming” Section III)

Programming a Keypad for Group Functions

* This section pertains only to Keypad Firmware Version 5.5 with Keypad Configuration Software Version 5.7

Setting the Keypad to have Group Functions:

- When programming the keypad to have group functions, it will allow you to select a group by using buttons #1-5 and then using buttons #6-8 to control the selected group. In this mode, when you press buttons #1-5 the corresponding LED will light for 12 seconds and you can use buttons #6-8 to control the group that is lit. If the LED goes out after 12 seconds, and buttons #6-8 are pressed, it will revert back to the last group that was selected.

Note: Once the "Group" selection is made in any "On Press" dropdowns in buttons #1-5, buttons #6-8 will become dedicated group control buttons and can not be used as standard SDN buttons. After the "Group" selection is made buttons #6-8 no longer support the sequence functions.

Programming the Buttons:

- Select "Group" in the "On Press" dropdown menu, as shown in button #1 below
- Once selected, it will open the "Specific Group" address box, as shown in button #3 below
- Enter the group address that you want the button to control
- Program buttons #6, 7 & 8 with the functions that you want to use to control the groups assigned to buttons #1-5.

Note: Group command functions will only work with group addresses. You can not use single motor addresses when programming buttons for groups. You will need to create a group for the single motor that you want to control, if using this feature.

The screenshot displays the keypad configuration software interface. At the top, it shows 'COM3' selected and 'COM Port Open'. Below this is a 'Configuration' section with buttons for 'Set Config', 'Get Config', 'Set Keypad Type', 'Set Group All Address', 'Save Settings', 'Import Settings', and 'Clear Data Field'. There are also radio buttons for 'Use Switch Address' and 'Motor All Address', and a text field for 'Address'. The main area is divided into several sections for different switches and DC motors: 'Switch, DC #1', 'Switch, DC #2', 'Switch, DC #3', 'Switch, DC #4', 'Switch, DC #6', 'DC #7', and 'DC #8'. Each section has a dropdown menu for 'On Press', 'On Hold', and 'On Release', and radio buttons for 'Group All', 'Specific Group', and 'Motor All'. In the 'Switch, DC #3' section, the 'On Press' dropdown is set to 'Group', and the 'Specific Group' radio button is selected, with an 'Address' text field below it. In the 'Switch, DC #6' section, the 'On Press' dropdown is also set to 'Group'. A red box highlights the 'Group' option in the 'On Press' dropdown of the 'Switch, DC #1' section. Another red box highlights the 'Specific Group' radio button and the 'Address' text field in the 'Switch, DC #3' section. A third red box highlights the 'Group' option in the 'On Press' dropdown of the 'Switch, DC #6' section.